



if it flows,
we go with it

1.800.665.4499
barrplastics.com

STANDARD SERIES: 17SCBV & QUIET SERIES: 17QSCBV

Quality Canadian Made



Combination Ball / Swing Check Valves



Standard series PVC combination ball / swing check valves allow for wastewater pumping applications requiring both in-line shut off and back flow prevention. Combination valves result in a more compact installation than two separate valves, ideal for installations where space is limited. The check valve features an angled seat, which shortens the travel distance of the flapper, minimizing flow reversal, noise and potentially damaging hydraulic shock (water hammer). This, coupled with corrosion resistant non-metallic components, results in a long lasting reliable valve.

Quiet series combination valves are a great solution for sump, sewage, pool and spa applications, ideal solution when extremely quiet operation is desired. Quiet series valves offer all the features as the standard series, with the addition of a spring loaded hinged flapper mechanism, which forces the flapper to fully close against fluid flow as the pump shuts down. This rapid closing action against pressure, before any flow reversal can occur, eliminates noise caused by hydraulic shock (water hammer).

Specification:

- Max Pressure: Valve bodies are rated 150 PSI Static Pressure @ 72°F (22°C) Non Shock
- Not recommended for use on systems exceeding 100 PSI at 120°F (48.8°C).
- Material: Type 1 Rigid Polyvinyl Chloride - ASTM-D1784
- Static Head: Minimum 2 feet
- Body: White

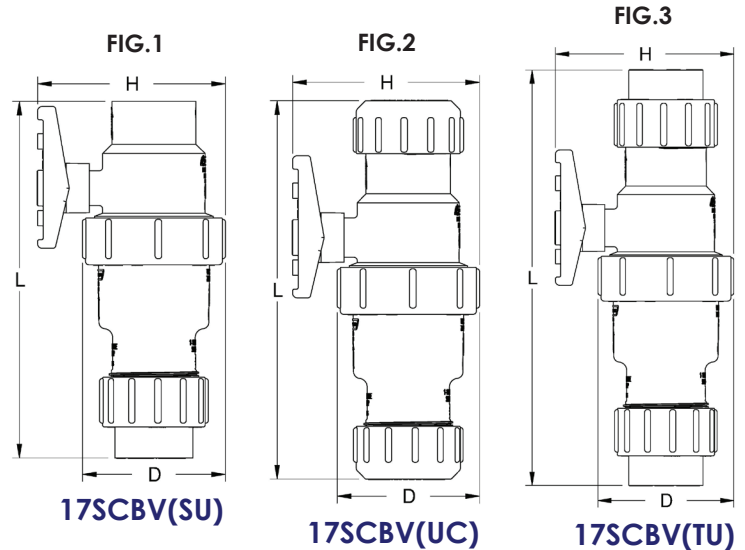

Fig. NO.	Part No.		Connections (IPS)		Body			Part Weight (lbs)
	Standard	Quiet	Inlet	Outlet	Length (in)	Height (in)	Diameter (in)	
1	17SCBV-15SU	17QSCBV-15SU	1-1/2" Slip Union	1-1/2" Slip	10.30	5.39	4.11	1.75
	17SCBV-20SU	17QSCBV-20SU	2" Slip Union	2" Slip	11.65	6.17	4.56	2.53
2	17SCBV-15UC	17QSCBV-15UC	1-1/2" Compression	1-1/2" Compression	10.93	5.39	4.11	1.98
	17SCBV-20UC	17QSCBV-20UC	2" Compression	2" Compression	11.90	6.17	4.56	2.78
3	17SCBV-15TU	17QSCBV-15TU	1-1/2" Slip Union	1-1/2" Slip Union	12.59	5.39	4.11	2.03
	17SCBV-20TU	17QSCBV-20TU	2" Slip Union	2" Slip Union	13.90	6.17	4.56	2.91



if it flows,
we go with it

1.800.665.4499
barrplastics.com

STANDARD SERIES: 17SCBV & QUIET SERIES: 17QSCBV

Quality Canadian Made



Combination Ball / Swing Check Valves

Features	Standard			Quiet		
	17SCBV(SU)	17SCBV(UC)	17SCBV(TU)	17QSCBV(SU)	17QSCBV(UC)	17QSCBV(TU)
Series:						
Full port design for less friction and easier pumping	✓	✓	✓	✓	✓	✓
True union design for servicing	✓	✓	✓	✓	✓	✓
Double O-ring valve seal on blow-out proof stem	✓	✓	✓	✓	✓	✓
Polyethelene ball valve seats	✓	✓	✓	✓	✓	✓
Durable ABS ball valve handle	✓	✓	✓	✓	✓	✓
Compatible with schedule 40 & 80 pipe	✓	✓	✓	✓	✓	✓
Designed for horizontal ◊ or vertical ◊◊ installation	✓	✓	✓	✓	✓	✓
Angled seat provides quiet operation by minimizing water hammer	✓	✓	✓	✓	✓	✓
Neoprene Seal	✓	✓	✓	✓	✓	✓
Low cracking pressure ensures minimal pressure drop across the valve (PSI)	0	0	0	1/2	1/2	1/2
Valve body designed for interchangeability between compression or ASTM-D2466 slip connections	✓	✓	✓	✓	✓	✓
Flexible PVC compression gaskets for easy sealing and pipe alignment		✓			✓	
Weighted Flapper Assembly	✓	✓	✓			
Spring Loaded Flapper Assembly				✓	✓	✓
S.S. Hinge Pin and Torsion Spring provide excellent corrosion resistance for longer life				✓	✓	✓
No metallic parts, corrosion resistant for longer life	✓	✓	✓			

◊ **IMPORTANT:** When pumping SOLIDS/SEMI SOLIDS valve must be installed HORIZONTALLY (up to 45° angle acceptable). Extra care must be taken to ensure the flow arrow points away from the pump AND the check valve body is oriented as per the marking on the valve body "HORIZONTAL USE THIS SIDE UP". Failure to position the swing check valve with the hinge of the flapper in the top center position will result in the valve not functioning properly.

◊◊ *Best practice is to install valves in the VERTICAL position when pumping SOLID FREE free liquids.*

Temperature Correction Factor for PVC Valves

As temperature increases, working pressure decreases. The optimal working pressure for PVC valves is 150 PSI @ 73°F (22°C)

If the temperature increases above 73°F (22°C), use the PVC correction factor to determine working pressure.

Multiply the maximum working pressure by the correction factor.

Temperature	73°F (22°C)	90°F (32°C)	100°F (38°C)	110°F (44°C)	120°F (49°C)	130°F (54°C)	140°F (60°C)
PVC Correction Factor	1.00	1.00	1.00	0.83	0.66	0.50	0.33