

TOPAZ FLOAT VALVE

PRODUCT INFO



Description

Topaz trough valves are float operated valves for use in automatic filling of water troughs, tanks, cisterns etc. The valve is configured for **above or below water mounting**. The float operates a small pilot valve which in turn operates the main diaphragm valve. Topaz trough valves are a good choice where their **high flow**, compact, robust, non corrosive construction and high level of adaptability are needed.

Applications

Maintaining Water Levels in:

- Animal Drinking Troughs
- Water Storage Tanks
- Water Cisterns
- Air Conditioning Systems
- High Pressure Cleaning Systems
- Irrigation Applications

Flow Graph

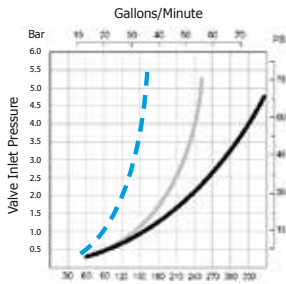

Key Flow Litres/Minute
 - 15mm (1/2")
 - 20mm (3/4")
 - 25mm & 32mm (1" & 1 1/4")

Features

- High flow
- Compact robust construction
- Mounts horizontally or vertically
- Made from corrosion resistant materials
- Shuts down slowly to minimise water hammer
- 20 - 60mm (3/4" - 2 1/2") water level differential (increases as water inlet pressure increases)
- Pressure rating 0.3 - 7 Bar (5 - 100 PSI)
- Float position easily adjustable with no tools
- Valve has switch to lock it in off position
- Has port to connect Frostpro anti freeze device

Mounting Positions

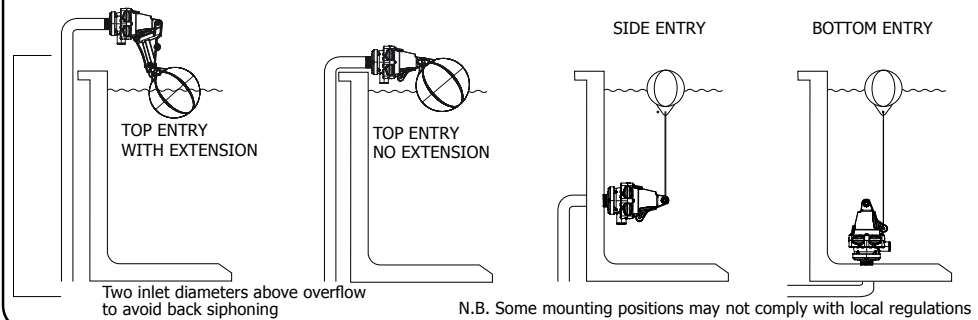

Options

	BSP				NPT				Long Tail: Supplied with backnut and seal washer.
Inlet Size	1/2"	3/4"	1"	1 1/4"	1/2"	3/4"	1"	1 1/4"	
Short Tail		✓	✓	✓		✓	✓	✓	
Long Tail	✓	✓	✓	✓	✓	✓	✓	✓	

	Floats: 125mm wide floats supplied standard. Note: Suitable for any mounting position 70mm and 95mm floats optional Note: Suitable for top entry only.	Standard	Optional	
	 125mm	 70mm	 95mm	

TOPAZ TROUGH VALVE SPECIFICATION

PRODUCT	CODE	INLET SIZE	CODE	OPTIONS	CODE
Topaz Trough Valve	TPV	1/2" bsp/npt	15	Detach Base	D
		3/4" bsp/npt	20	Long Tail Thread	LT
		1" bsp	25		
		1" npt	1	70mm wide Float	F70
		1 1/4" bsp	32	95mm wide Float	F95
		1 1/4" npt	114		

(e.g) A Topaz Trough Valve with: 3/4" bsp inlet thread, detach base, long tail thread has the following spec number: TPV 20 D LT
 NOTE: If no options are specified the standard ones will be supplied

Note: Product may differ slightly from these specs due to ongoing product development.

200 L / MIN

TOPAZ FLOAT VALVE

DIMENSIONS & MATERIALS



200 L / MIN

Topaz Dimensions

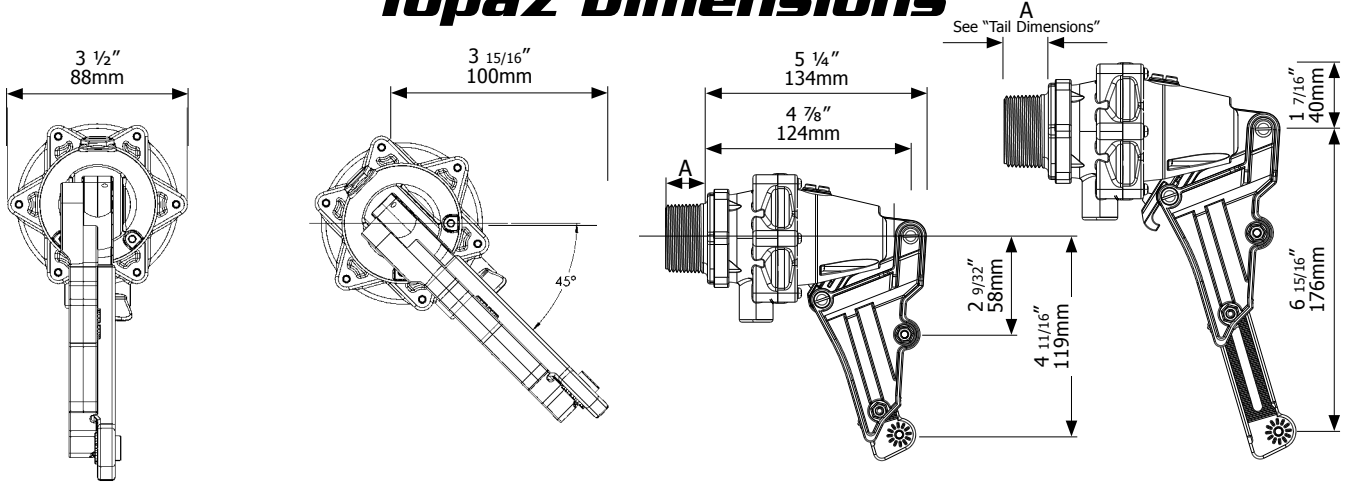

Float Dimensions

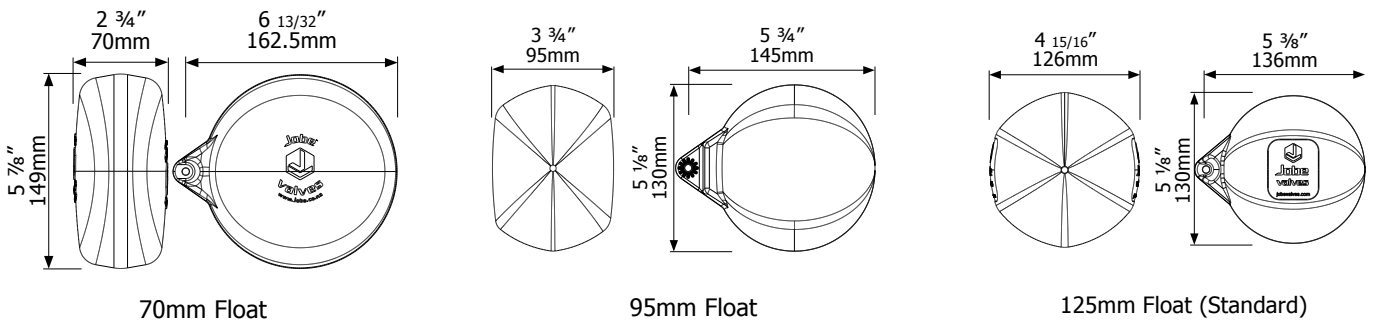

Part	Material	Part	Material
Valve Body & Tail	<i>Glass Filled Nylon</i>	Float Cord	<i>Polyester</i>
White & Yellow Internal Parts	<i>Acetal</i>	Springs, Bolts, Nuts, Pin, Screws	<i>304 Stainless Steel</i>
Filter	<i>PP/Nylon</i>	O'Rings	<i>Nitrile</i>
Diaphragm	<i>EPDM</i>	Float	<i>HDPE</i>
Seal	<i>Urethane</i>	Actuator / Arms & Caps	<i>ABS</i>

Tail Dimensions		
Dimension A	mm	inches
20mm (3/4") Short tail	22	7/8
25mm (1") bsp/npt short tail	22	7/8
32mm (1 1/4") bsp/npt short tail	25	1
15mm (1/2") long tail	100	4
20mm (3/4") long tail	38	1 1/2
25mm (1") bsp/npt long tail	54	2 1/8
32mm (1 1/4") bsp/npt long tail	60	2 3/8

Maximum Operating Temperature

60°C, 140°F

TOPAZ FLOAT VALVE

PARTS IDENTIFICATION SHEET

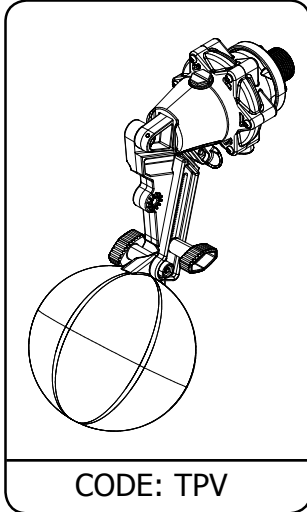

CODE: TPV

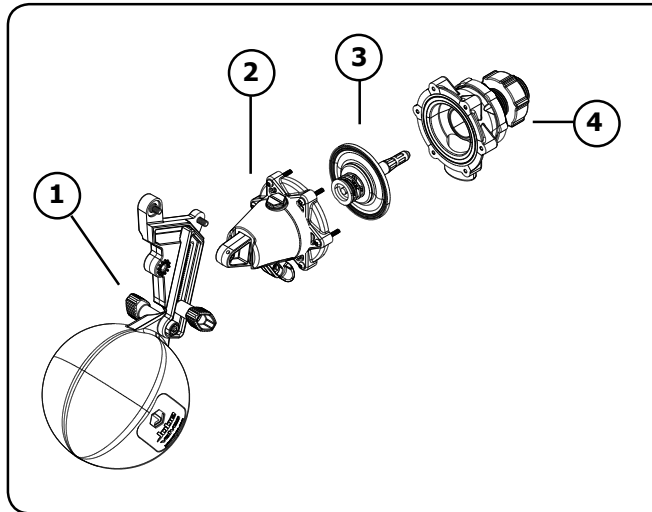

CODE	DESCRIPTION
1	Float Assembly
2	TPP2 Cap & Actuator Assembly
3	TPP3 Diaphragm Assembly
4	Detach Base Assembly

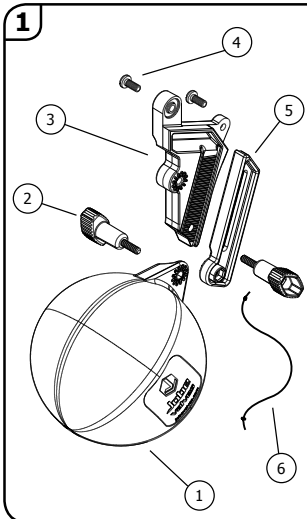

CODE	DESCRIPTION
1	TPP10110 70mm Float TPP10115 95mm Float TPP10120 125mm Float
2	TPP1020 Wing Bolt
3	TPP1030 Extension Arm
4	TPP1040 Bolt M5 x 12 Pan Slot
5	TPP1050 Extension Slide
6	TPP1060 Float Cord

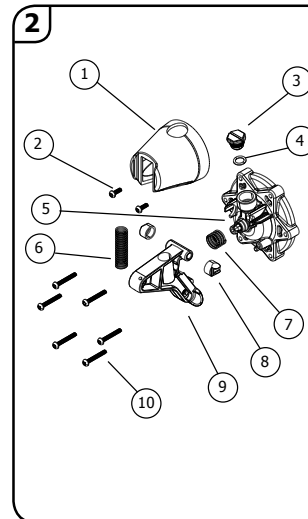

CODE	DESCRIPTION
1	TPP2010 Actuator Cap
2	TPP2020 6g x 10 S/S Screw
3	TPP2030 Frost Pro Plug
4	TPP2040 Frost Pro O'ring
5	TPP2050 Valve Cap Assembly
6	TPP2060 Actuator Spring
7	TPP2070 Damping Spring
8	TPP2080 Bearings (set of two)
9	TPP2090 Actuator Arm
10	TPP2100 6g x 25 S/S Screw

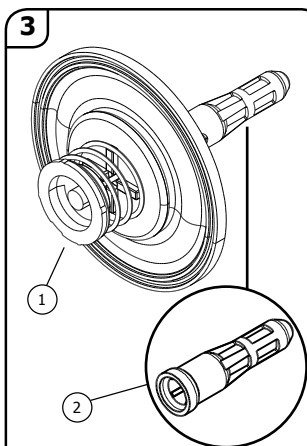

CODE	DESCRIPTION
1	TPP3 Diaphragm Assembly
2	TPP3010 Pilot Flow Filter (Fine) TPP3011 Pilot Flow Filter (Coarse)

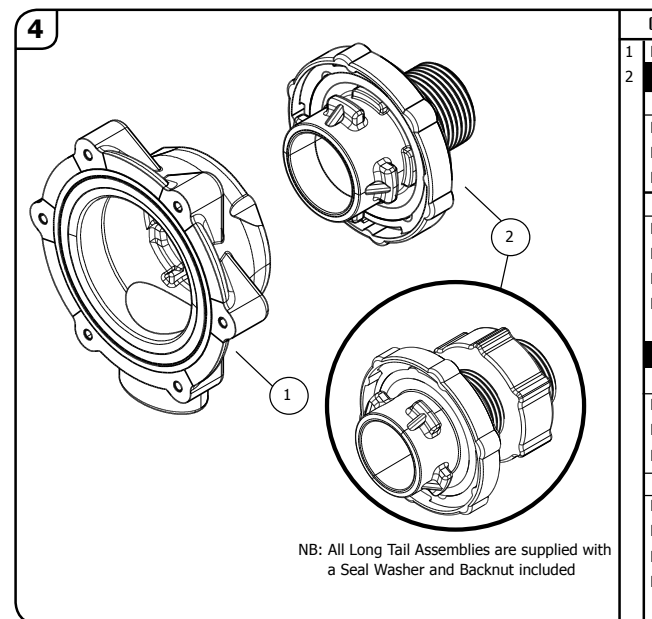

CODE	DESCRIPTION
1	DTP1 Detach Base
2	BSP Tails
	Short Tail Assembly (BSP)
DTP020	Detach Tail 20mm(3/4") Short
DTP025	Detach Tail 25mm(1") Short
DTP032	Detach Tail 32mm(1 1/4") Short
	Long Tail Assembly (BSP)
DTP015L	Detach Tail 15mm (1/2") Long
DTP020L	Detach Tail 20mm (3/4") Long
DTP025L	Detach Tail 25mm (1" bsp) Long
DTP032L	Detach Tail 32mm (1 1/4" bsp) Long
	NPT Tails
	Short Tail Assembly (NPT)
DTP0075	Detach Tail 3/4" npt
DTP0100	Detach Tail 1" npt
DTP0125	Detach Tail 1 1/4" npt
	Long Tail Assembly (NPT)
DTP0050L	Detach Tail 1/2" npt Long
DTP0075L	Detach Tail 3/4" npt Long
DTP0100L	Detach Tail 1" npt Long
DTP0125L	Detach Tail 1 1/4" npt Long

200 L / MIN