



if it flows,
we go with it

1.800.665.4499
barrplastics.com

© DEN HARTOG INDUSTRIES, INC.

Copyright. All information furnished within this document, electronic file or design correspondence is the property of Den Hartog Industries, Inc. and shall not be used, disclosed to others or copied without the expressed written consent of Den Hartog Industries, Inc.

SP0200-RT

A

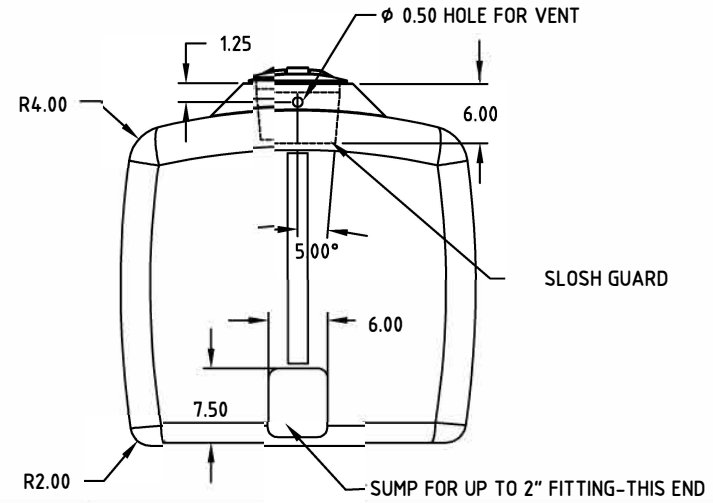
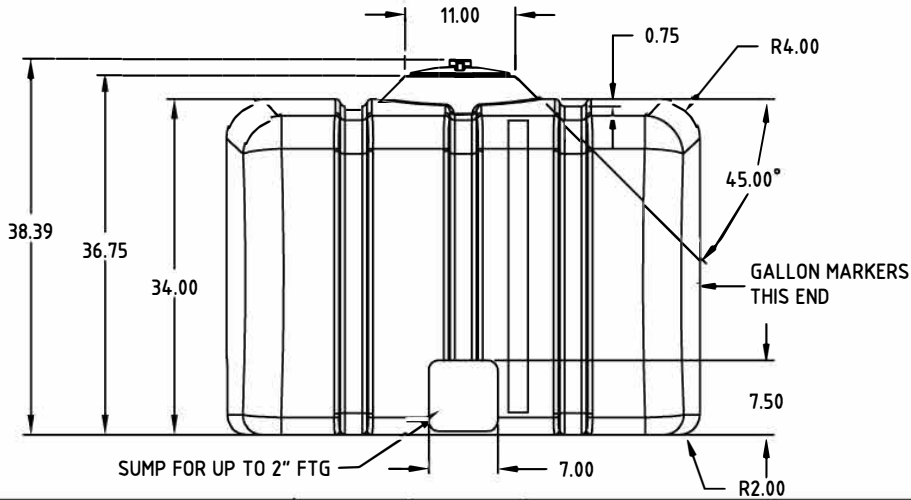
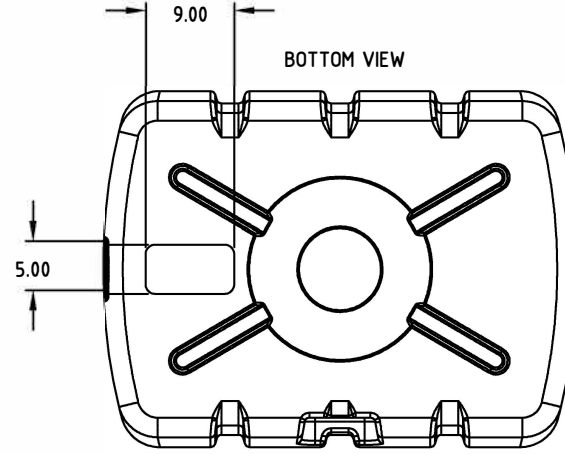
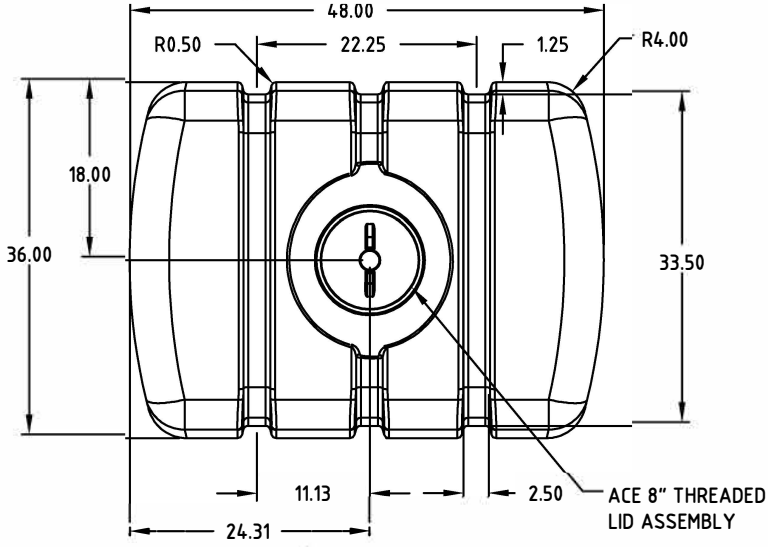

				DRAWN / DATE REH / 4/19/99	MATERIAL MOBIL 134
A	GALLON MARKER LOCATION ADDED TO PRINT	ADH 12/10/09	1980	APPRD. / DATE REH / 4/19/99	
REV	DESCRIPTION	BY / DATE	CCN		
ALL DIMENSIONS ARE IN DECIMAL INCHES TOLERANCES UNLESS OTHERWISE SPECIFIED		THIRD ANGLE PROJECTION ANSI 14.5M		SHOT WEIGHT: 80 LB.	NOTES: 1.) NATURAL COLOR 2.) NOM. WALL .270
POLYETHYLENE ±1% @ 68° F		METAL DECIMAL ± .125" FRACTION ± 1/4" ANGLE ± 1°		SHIPPING WEIGHT:	
		FINISH:			



1.800.665.4499
barrplastics.com

Ace Rotomold Injection Molding Blow Molding SawJoy
4010 HOSPERS DRIVE S. BOX 425, HOSPERS, IOWA 51238-0425

DESCRIPTION	200 GAL. TANK	
SCALE	N.S.	PART NO. SP0200-RT