

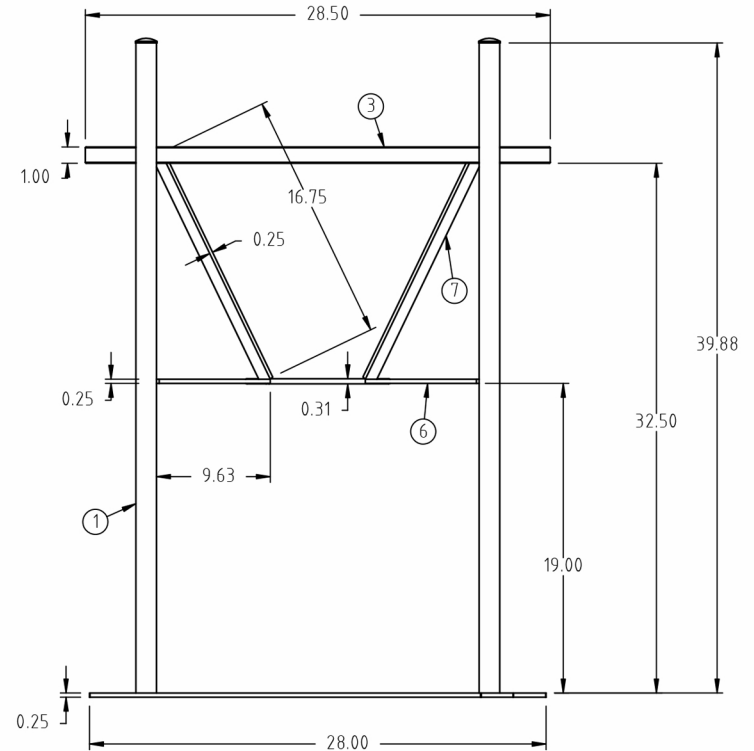

1.800.665.4499
barrplastics.com

INFD40/85-ST

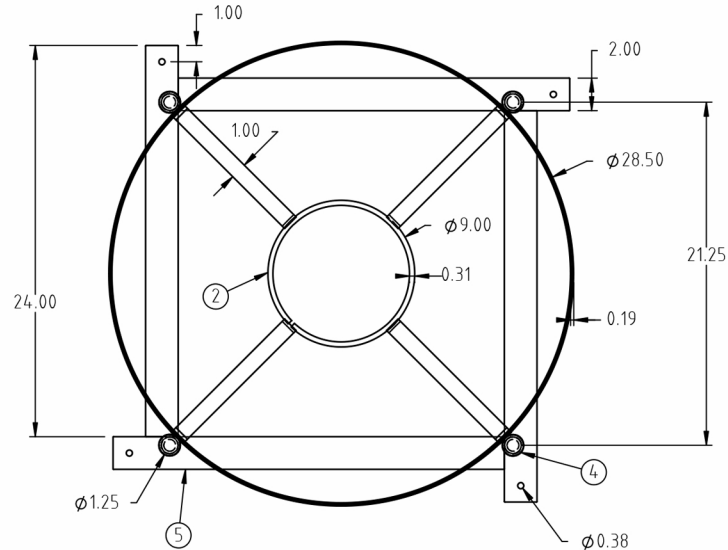

				DRAWN / DATE ADH 11/20/15	MATERIAL
				APPRD. / DATE REH 12/14/15	
REV	DESCRIPTION	BY / DATE	CCN		
ALL DIMENSIONS ARE IN DECIMAL INCHES TOLERANCES UNLESS OTHERWISE SPECIFIED		THIRD ANGLE PROJECTION ANSI 14.5M		SHOT WEIGHT:	NOTES:
POLYETHYLENE ±1% @ 68°F		METAL DECIMAL ± .125" FRACTION ± 1/4" ANGLE ± 1°		SHIPPING WEIGHT: 49 LBS	
				FINISH: POWDER COATING, BLACK TILE, 40012	



Den Hartog
INDUSTRIES, INC.

Ace Roto-Mold Injection Molding Blow Molding Sowjoy

4010 HOSPERS DRIVE S. BOX 425, HOSPERS, IOWA 51238-0425

DESCRIPTION 40,85, OR 110 GALLON FULL DRAIN INDUCTOR STAND

SCALE N.S.

PART NO. INFD40/85-ST